

Usage of Distribution Box Switches

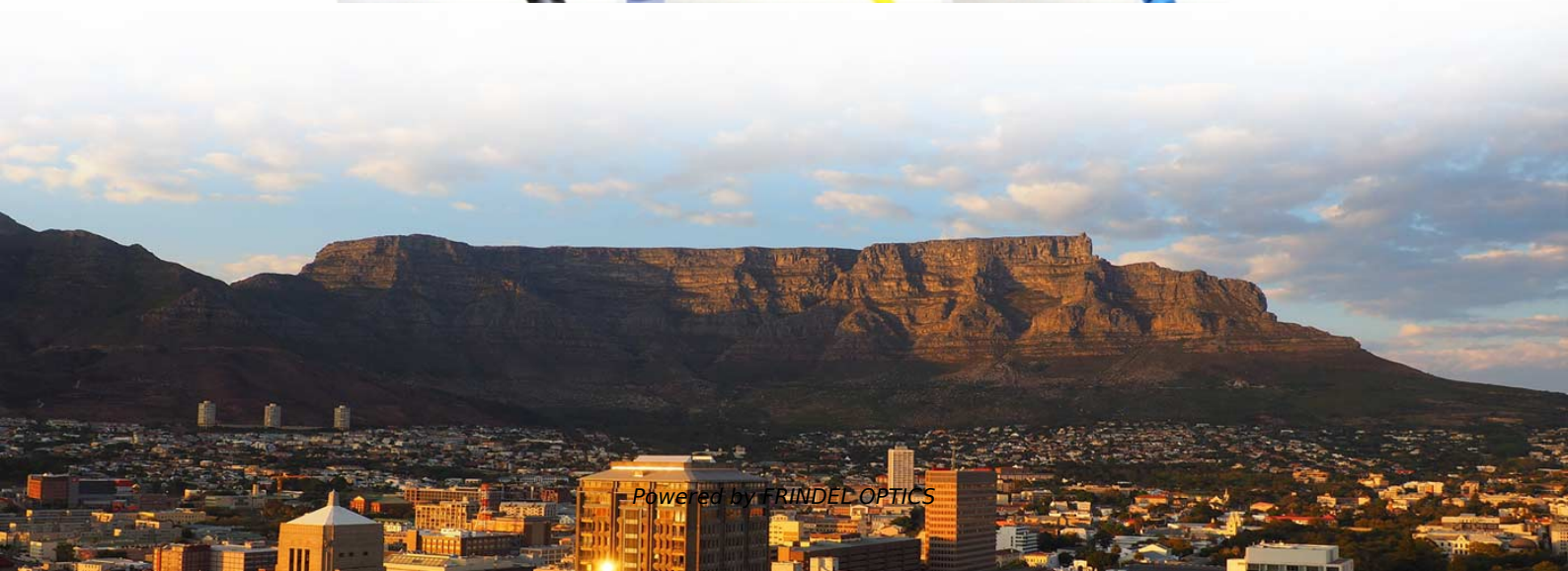



Usage of Distribution Box Switches



Ultimate Guide To Distribution Boxes Db Boxes Types

This ultimate guide explains what a distribution box does, its internal components, common types, real-world applications, and how to select the right DB Box for

[Contact Us](#)

Distribution Boxes: Types and Functions

Learn what an electrical distribution box (DB/distribution board) is, its main components (MCB/RCCB/RCBO, SPD, busbar) and common types.

[Contact Us](#)



Comprehensive Understanding of Distribution Box

Using a distribution box that meets safety rules gives peace of mind. Always pick one with proper certifications for your area. Energy efficiency and control In 2025, saving energy is very important. A

[Contact Us](#)



Distribution Box vs Control Box vs Junction Box: Key

Learn the differences between distribution boxes, control boxes, and junction boxes. Discover their functions, applications, and how E-abel provides



Distribution Board vs. Distribution Box: What's the

Understand the key differences between distribution boards and boxes--functions, applications, safety, cost, and when to use each one.

[Contact Us](#)

Distribution Box Industry Comparison of Types and Uses

Compare types and uses of distribution boxes in the distribution box industry, covering residential, commercial, and industrial applications.

[Contact Us](#)



Understanding Distribution Boxes: A Comprehensive Guide

In general, a distribution box is mainly used to distribute electrical power to multiple circuits and provide circuit protection. An electrical panel may

[Contact Us](#)



what is a Distribution Box

In electrical systems, a distribution box, also known as a breaker box or distribution board, plays a critical role in managing and distributing electrical

[Contact Us](#)



Distribution Boxes Explained: Types, Functions, and

Learn about distribution boxes, their types, functions, and safety features to ensure efficient and secure electrical power distribution in any building.

[Contact Us](#)



The Importance of Isolation Switches in Distribution Boxes

Isolation switches in distribution boxes ensure electrical safety by disconnecting circuits for maintenance, preventing shocks, aiding compliance,

[Contact Us](#)

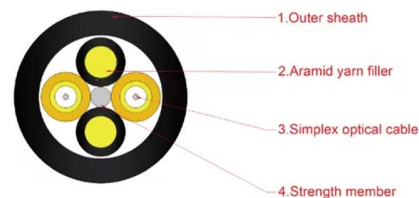

A Definitive Guide To Distribution Boxes

The distribution box acts as the center of power distribution, distributing electricity to all connected devices. A distribution box, also known as a distribution board, panel board, breaker

[Contact Us](#)





What is the difference between a distribution box and a switch box

The proper use of distribution and switchgear cabinets The difference between a distribution box and a switchboard revolves around their respective functions and applications. A

[Contact Us](#)



What is an Electrical Distribution Box? A

Opening up an electrical distribution box might look like stepping into a maze of wires, switches, and mysterious gadgets. But each component plays a

[Contact Us](#)



The purpose, working principle, and usage instructions

During normal operation, the circuit can be connected or disconnected using manual or automatic switches. When there is a malfunction or

[Contact Us](#)



Distribution Boxes Types - The Complete Guide

The power distribution boxes deliver electricity from the main electrical main to other circuits. Several distribution boxes are designed for specific use in

[Contact Us](#)

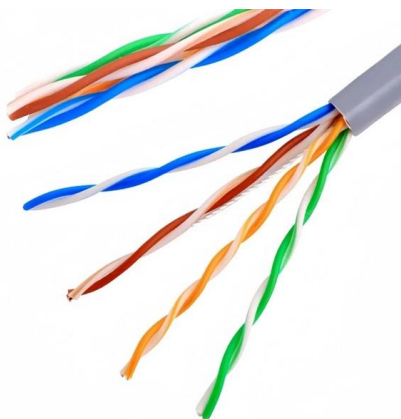



Explore Power Distribution Box Types and Functions

Distribution boxes vary in shape and structure due to different usage scenarios and requirements, but the basic components include fuses, circuit

[Contact Us](#)

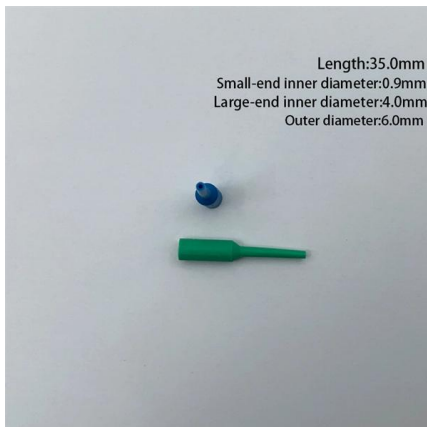

Distribution Boxes Types - The Complete Guide

Most people use them for the ease of controlling multiple power distribution from the main electrical power distribution board. Additionally, the

[Contact Us](#)

Ultimate Guide To Distribution Boxes Db Boxes Types

Introduction For procurement professionals, electrical contractors, and project managers, choosing the right Distribution Box (DB Box) is a critical decision that

[Contact Us](#)

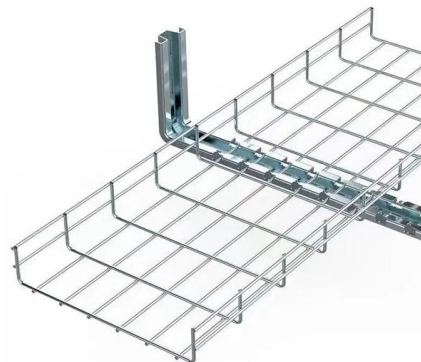

The Complete Guide to Distribution Box: Installation, Types & More

The main switch, or main breaker, controls the entire electrical supply to the distribution box. This large switch allows you to disconnect all power to the building during emergencies or

[Contact Us](#)



The Complete Guide to Distribution Box: Installation, Types & More

Each element plays a specific role in ensuring safe electrical distribution. The main switch, or main breaker, controls the entire electrical supply to the distribution box. This large switch allows

[Contact Us](#)

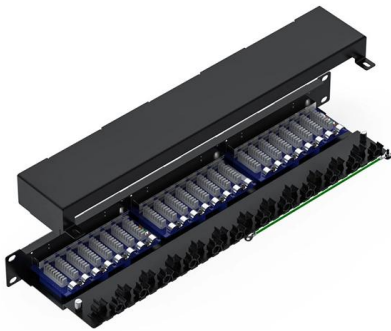

Complete Guide For Distribution Boxes Types

Distribution boxes, also known as electrical distribution boards or panels, are pivotal components in electrical systems, ensuring the safe and organized distribution of

[Contact Us](#)

The Importance of Distribution Boxes in Electrical Systems

Learn more about how distribution boxes play a critical role in the safe and efficient operation of electrical systems.

[Contact Us](#)

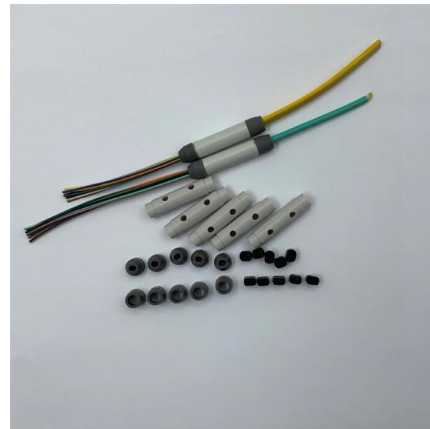

Distribution Box Guide: Types, Components & Solutions

Understand distribution boxes (DB boxes) in 5 minutes. Learn about types, components, functions, and uses. Find the perfect DB box for your needs.

[Contact Us](#)



Contact Us

For datasheets, pricing, or custom fiber access solutions, please visit:
<https://www.frindel.es>