

The function of the spiral cable in the distribution box





The function of the spiral cable in the distribution box



Understanding Distribution Boxes: A Comprehensive Guide

A distribution box, also known as a power distribution box or electrical distribution box, is used to distribute electrical power safely to multiple

[Contact Us](#)

Distribution Box Guide: Types, Components & Solutions

It acts as a protective enclosure that houses several key components, such as circuit breakers, fuses, and bus bars. These components work together

[Contact Us](#)



Comprehensive Understanding of Distribution Box

A distribution box helps manage electricity in homes or workplaces. It makes sure power flows safely and efficiently to devices. Let's look at its main jobs. Power distribution and circuit management The

[Contact Us](#)

What Is an Electrical Distribution Box and Why Is It

An electrical distribution box distributes power safely, prevents overloads, and protects circuits, ensuring efficient and reliable electrical systems.

[Contact Us](#)



What Is a Spiral Cable and Its Main Uses

Discover what a spiral cable is, how it works, its materials, uses, types, and pricing. Learn why Sino-conn is your trusted custom spiral cable supplier.

[Contact Us](#)



What is the function of a distribution box?

1. Centralized Control and Distribution The main function of a Distribution Box is to act as a central hub. The single, thick cable bringing power from the utility company enters this box. Inside,

[Contact Us](#)



Custom What is Spiral Wire Used For?

The spiral cable design gives the mobility and durability needed for components that move around a lot. Plus, because they're coiled, these wires stay organized, reducing the chances of

[Contact Us](#)





how does a power distribution box work

The distribution box is a very important component of the power system. It is responsible for transmitting electrical energy from the power station

[Contact Us](#)



Distribution Board vs Distribution Box: What are the

For electrical systems, people use and confuse the terms distribution box and distribution board for each other. However they feature unique

[Contact Us](#)

Understanding Distribution Boxes: Your Guide to Power

Understanding distribution boxes: Your guide to power distribution. Learn about power distribution box functions and shop power distribution options.

[Contact Us](#)



Integrated Aluminum Alloy Die Casting



What Is an Electrical Distribution Box? A Complete Guide

Key Functions and Benefits The electrical distribution box serves a critical role in the safe distribution of power by centralizing circuit control and

[Contact Us](#)

Durable and Secure Metal Screws





Cable assembly: Spiral cables

For automation technology we spiralize encoder / motor / BUS cables and thus ensure tidy cable lengths. We manufacture with small minimum quantities and

[Contact Us](#)



Explore Power Distribution Box Types and Functions

Power distribution boxes are used in commercial and residential buildings and are part of the electrical system, also known as switchboards.

[Contact Us](#)

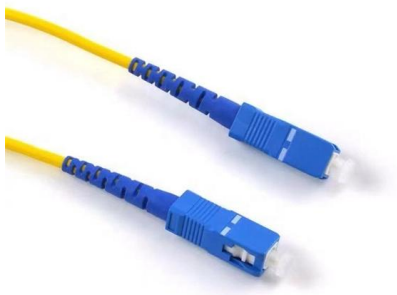

Size determination, installation method and wiring mode

The distribution box is the central hub of the home circuit and the general control of our daily power consumption. It is an indispensable electrical equipment. If there

[Contact Us](#)



Spiral Cable Knowledge Sharing: Structure, Types, and Applications

Spiral Cable Knowledge Sharing: Structure, Types, and Applications In modern electronics and industrial production, spiral

[Contact Us](#)

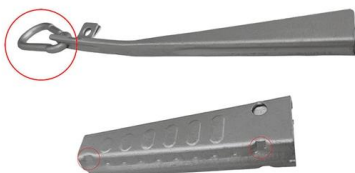



What Is a Distribution Box?

What to Look for When Choosing a Distribution Box If you're going to buy a distribution box, there are several things you should look for. You should

[Contact Us](#)

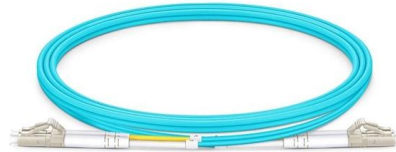

What is a Spiral Cable Assembly?

Spiral cable assemblies keep workspaces organized and reduce equipment downtime from wire failures. The spring-back action prevents tangling and eliminates slack cable management issues.

[Contact Us](#)

The essentials of radial distribution system and its

The distribution transformers are connected to the primary feeders, subfeeders, and laterals, usually through fused cutouts, and supply the radial

[Contact Us](#)

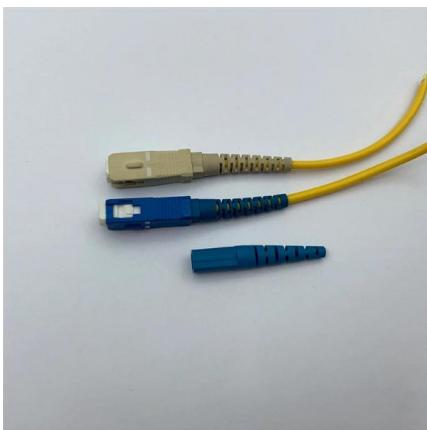

Guide to spiral cable wrap , Essentra Components US

Its main job is to take the incoming power supply and distribute it to multiple circuits within the building, ensuring that electricity is delivered safely to

[Contact Us](#)



Distribution Boxes Explained: Types, Functions, and

Learn about distribution boxes, their types, functions, and safety features to ensure efficient and secure electrical power distribution in any building.

[Contact Us](#)

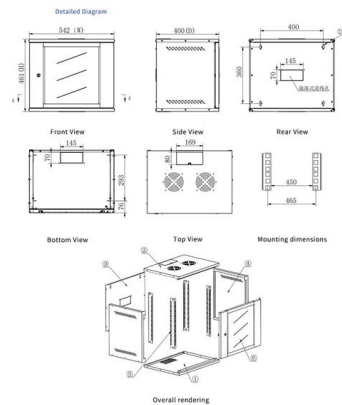

How to Install a Cable Distribution Box Safely and

Function: Cable distribution boxes are mainly used for power distribution, circuit protection, and cable management, with built-in protective

[Contact Us](#)

What is a Distribution Box? - A Comprehensive Guide

This challenge led to the invention of the distribution box, a game-changer in electrical systems. So, what is a distribution box? It organizes and

[Contact Us](#)



Spiral Cable Knowledge Sharing: Structure, Types, and

What is the Function of a Spiral Cable? The primary function of spiral cables is space-saving and maintaining order. Their stretchable design prevents

[Contact Us](#)



What Is a Spiral Cable and Its Main Uses

What exactly is a spiral cable? A spiral cable is a coiled wire designed to stretch and retract, maintaining reliable electrical connections during

[Contact Us](#)

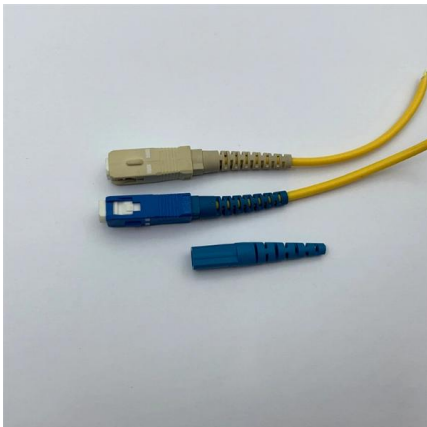
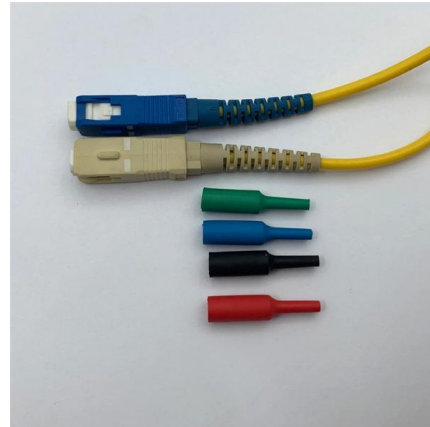

Distribution Box: Types and Functions , Axis-Electricals

They are generally used as a distribution box during a main upstream breaker. Line wires are connected to these lugs, and the main lug panel can be used as a sub

[Contact Us](#)

Power Distribution Boxes Explained Simply

Discover the essentials of a Power Distribution Box--how it works, key types, benefits, and tips to ensure safe, efficient electrical power management.

[Contact Us](#)



Spiral Cable

Spiral cable is a type of equipment connection cable that utilizes stretchability to work. This type of cable can save a lot of space.

[Contact Us](#)



Contact Us

For datasheets, pricing, or custom fiber access solutions, please visit:
<https://www.frindel.es>