



FRINDEL OPTICS

How to install a motor distribution box





How to install a motor distribution box



Power Distribution Box : 5 Steps (with Pictures)

Power Distribution Box: For starters, I built a rack for my truck to throw some "off road" lights on. I wanted a box to control these and some reverse lights. I also got

[Contact Us](#)

The installation requirements for the distribution box

Learn how to install a distribution box safely and correctly. Covers wiring, placement, standards, and expert tips for a compliant setup.

[Contact Us](#)



How to install electrical distribution box quickly?

How to install electrical distribution box quickly? Enclosure E-Abel 1.07K subscribers [Subscribe](#)

[Contact Us](#)

Step-by-Step Guide to Install MCB Distribution Box

How to Install an MCB Distribution Box Safely: A Step-by-Step Guide Electricity safety is the backbone of operational efficiency in today's fast-paced industrial



Electric distribution box wiring tutorial (very simple and practical)

In this video, we are going to wire a power distribution box. This small box has an rccb switch that protects the outputs from electric shock and also has a miniature switch that protects the

[Contact Us](#)

The Best Solution to Install Components Inside The

The trickiest part of installing inner components of a distribution box is that the components' heights are irregular. E-Abel's flexible mounting bracket can

[Contact Us](#)



What hand and power tools are used to install a

Install distribution box systems with essential hand tools like screwdrivers and pliers, plus power tools such as drills and impact drivers for efficient setup.

[Contact Us](#)





Install a Distributor Correctly the First Time

Engine Power shows you how to install an engine distributor correctly, the first time and every time.

[Contact Us](#)



How to Install a Distributor and Set Initial Timing

In this detailed walkthrough, we show you how to install & adjust your engine's distributor to set initial timing the correct way.

[Contact Us](#)

How to Install a Distribution Box in Singapore?

Guide to distribution box installation in Singapore, covering planning, wiring, circuit setup and safety. Ensure proper setup or consult a licensed electrician.

[Contact Us](#)



How to Wire 3-Phase, 400V Distribution Board? IEC

Wiring a 3-Phase, 400V Distribution Board: UK & EU - IEC. How to Wire a Three-Phase Distribution Board for 400V Load Circuits and MCB's?

[Contact Us](#)

SP-JXF 3 Phase Motor Circuit Control Low



Voltage

PRODUCT OVERVIEW SP-JXF low-voltage distribution box is applicable to three-phase three-wire, three-phase four-wire and three-phase five-wire systems of

[Contact Us](#)



on video **How to Wire a Home Distribution Box**

How to Wire a Home Distribution Box - Step-by-Step , Distribution DB box wiring diagram Welcome to our channel! In this video, we'll walk you through the

[Contact Us](#)

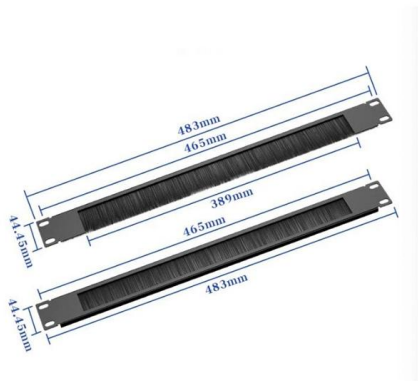

Distribution Box Installation: Advanced Techniques

Distribution Box Installation: Advanced Techniques. The installation of a distribution box is explored in detail, highlighting advanced techniques for achieving a professional and

[Contact Us](#)



How to Install a Distribution Box--A Comprehensive

Before starting the installation, finding a proper place for putting the distribution box is crucial, because it largely decides the safety and convenience

[Contact Us](#)





Small distribution box installation steps

The steps to install a small distribution box include selecting a suitable location, installing the base, placing the distribution box, connecting the

[Contact Us](#)



Length:14.5mm
Small-end inner diameter:2.0mm
Large-end inner diameter:3.5mm
Outer diameter:5.2mm



Understanding Distribution Boxes: A Comprehensive Guide

A distribution box, also known as a power distribution box or electrical distribution box, is used to distribute electrical power safely to multiple

[Contact Us](#)

The Complete Guide to Distribution Box: Installation, Types & More

A well-chosen and properly installed distribution box can prevent electrical hazards, reduce downtime, and ensure your electrical system operates smoothly

[Contact Us](#)

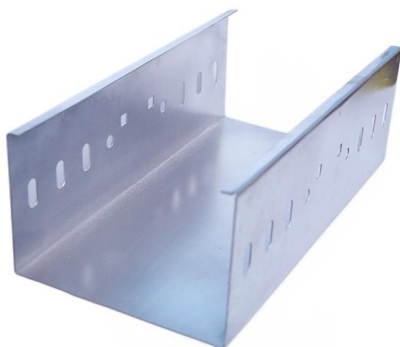

How to Wire a Home Distribution Box

Main Distribution Board (MDB) is also known as Fuse board or consumer unit where the main protective and isolation devices are installed to

[Contact Us](#)

How to Wire a Home Distribution Box



Welcome to our channel! In this video, we'll walk you through the process of wiring a home distribution box with a detailed connection diagram.

[Contact Us](#)



The Complete Guide to Distribution Box: Installation, Types & More

Proper installation of a distribution box requires careful planning and adherence to electrical codes. While major installations should always involve qualified electricians, understanding

[Contact Us](#)

A Step-by-Step Guide to Wiring an Electrical Panel Box

A Step-by-Step Guide to Wiring an Electrical Panel Box An electrical panel box, also known as a breaker box or a distribution board, is a crucial component of any

[Contact Us](#)



Installing a Terminal Box onto the Motor/Gearmotor (IP-44)

The motor/gearmotor is factory installed with a bushing on the lead exit. In order to install the terminal box onto the motor/ gearmotor, this bushing must be removed.

[Contact Us](#)



Distribution Box Installation: A Complete Guide to Safe

The distribution box, often referred to as a breaker box, fuse box, or electrical panel, is a critical component of any electrical system. It acts as the central hub for

[Contact Us](#)



Contact Us

For datasheets, pricing, or custom fiber access solutions, please visit:
<https://www.frindel.es>