

House Electrical Distribution Box Planning

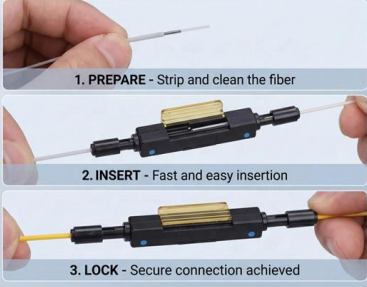



EFFICIENT FIELD TERMINATION



1. **PREPARE** - Strip and clean the fiber

2. **INSERT** - Fast and easy insertion

3. **LOCK** - Secure connection achieved

No Polishing | No Epoxy

Eliminates cable excess length and pigtail splice storage.
Designed for high-efficiency onsite installation.



House Distribution Board » Wiring Diagram

A house distribution board is a vital component of any electrical system. By understanding the components of a house distribution board,

[Contact Us](#)

Power Distribution Boxes Explained Simply

Discover the essentials of a Power Distribution Box--how it works, key types, benefits, and tips to ensure safe, efficient electrical power management.

[Contact Us](#)



The Complete Guide to Distribution Box: Installation, Types & More

A distribution box, also known as a distribution board, electrical panel, or breaker box, is an enclosure that houses electrical components responsible for distributing electricity throughout a

[Contact Us](#)



How to Create an Electrical Plan for Your Home

An electrical plan translates power distribution into a concrete, readable design overlaid onto the architectural floor plan. The plan must clearly indicate the placement of all receptacles,

[Contact Us](#)

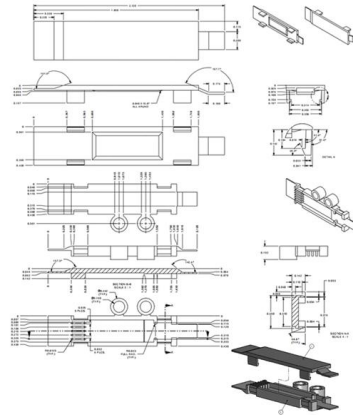

Electrical panels 101: a beginner's guide to your home's

Learn what your electrical panel does, how circuits and amps work, and how to plan upgrades--plus expert advice on smart panels and panel capacity.

[Contact Us](#)

From the Ground Up: Electrical Wiring

Read our guide to electrical wiring, covering layout, materials, safety, and planning for a safe, efficient home system.

[Contact Us](#)



The Essential Guide to Understanding Electrical

Learn about the components and layout of an electrical distribution system diagram, including transformers, circuit breakers, and distribution panels.

[Contact Us](#)



12 types of distribution boxes and how to choose them

Choosing the best distribution box isn't rocket science, but it does need a bit of thought. I'll walk you through the key factors to consider, like your building size, budget, and environment.

[Contact Us](#)



How to Choose a House Distribution Box , CHINT global

A well-chosen distribution box ensures the safety and efficiency of your household electrical system. This article guides you through selecting a

[Contact Us](#)

House Electrical Plans: Ensuring Safety and Efficiency

Electrical plans and flowcharts solve different visual tasks. Electrical layouts show wiring, outlets, and equipment placement, while flowcharts are used to represent

[Contact Us](#)

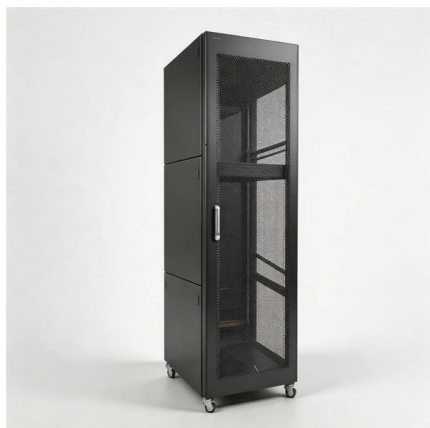

Distribution Box Installation: A Complete Guide to Safe

The distribution box, often referred to as a breaker box, fuse box, or electrical panel, is a critical component of any electrical system. It acts as the central hub for

[Contact Us](#)



How Do I Plan the Electrical Wiring for My Home?

How to plan the electrical layout for a house Do you have a comprehensive understanding of the electrical requirements

[Contact Us](#)



House Electrical Wiring layout

House electrical wiring layout is a blueprint for electrical wiring. It defines layout for lights, fans, switch boards with control panel.

[Contact Us](#)

Size determination, installation method and wiring mode

The distribution box is the central hub of the home circuit and the general control of our daily power consumption. It is an indispensable electrical equipment. If there

[Contact Us](#)



Electrical planning for a modern detached house in 10

Here, nothing works without electrical planning: New construction of an upscale detached house with a large open area with electrical installation pipes, boxes for

[Contact Us](#)



How to Choose the Right Distribution Box for Your Home or Workshop

Learn how to choose the right distribution box for your home or workshop. Discover sizing rules, component selection, and strict electrical safety standards.

[Contact Us](#)



Single Phase Distribution Board Wiring Diagram

Today i am gonna to tech you about single phase distribution board wiring diagram and instillation with video tutorial guide. In electrical and House

[Contact Us](#)

The installation requirements for the distribution box

A distribution box is the heart of any electrical system. It takes the incoming power and safely distributes it to different circuits throughout your

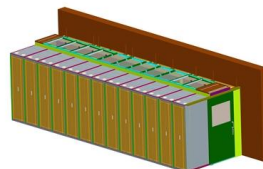

[Contact Us](#)



The installation requirements for the distribution box

Learn how to install a distribution box safely and correctly. Covers wiring, placement, standards, and expert tips for a compliant setup.

[Contact Us](#)



How to Choose a Home Distribution Box - Expert Guide

Learn how to choose the right home distribution box with our expert guide. Compare circuit capacity, IP ratings, breaker types & avoid common mistakes.

[Contact Us](#)



What is an Electrical Distribution Box? A

When it comes to electrical safety, every building -- whether it's a cozy home or a sprawling factory -- needs a secure system to manage and

[Contact Us](#)

House Electrical Plan Drawing: 5 Steps

See how to draw electrical plans the easy way! Here's how to leverage modern software to design accurate electrical layouts fast & avoid costly

[Contact Us](#)



An Ideal House Electrical Layout Plan

Proper planning and installation of house electrical layout plan are critical to ensure the house is safe and up to code.

[Contact Us](#)



The Complete Guide to Distribution Box: Installation, Types & More

Proper installation of a distribution box requires careful planning and adherence to electrical codes. While major installations should always involve qualified electricians, understanding

[Contact Us](#)

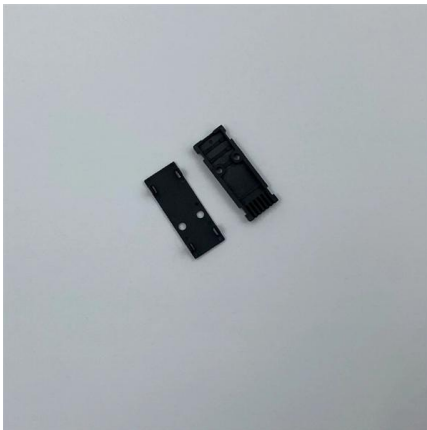

Electrical Distribution Panel Design Guide

This document outlines the design and functionality of electrical distribution panels, detailing their types, key features, and operational mechanisms. It emphasizes

[Contact Us](#)

Contact Us

For datasheets, pricing, or custom fiber access solutions, please visit:
<https://www.frindel.es>