

Functions of Andorra Explosion-proof Distribution Box

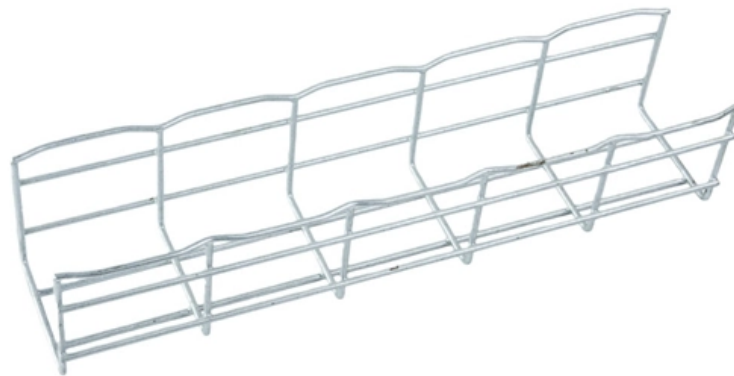



Overview

The enclosures are certified Ex d IIB+H2 and Ex tb as well as "explosion-proof". They are available in many sizes, a wide range of operating elements and monitoring functions can be integrated. ·Flameproof enclosure (Ex db), which can be used as feed distribution equipment in control and distribution system (such as distribution box, switch box of main circuit, control box, terminal box or motor starting box etc. That's where explosion-proof distribution boxes become the unsung heroes of industrial safety.



Functions of Andorra Explosion-proof Distribution Box



BXM (D)51 Series Explosion proof Distribution Boxes

BXM (D)51 Explosion proof Distribution Boxes
Explosion protection to -CENELEC -IEC -NEC Can
be used in Zone 1 and Zone 2 Zone 21 and Zone
22 Class I, Zone

[Contact Us](#)

BXM (D)8050 Explosion proof Distribution Boxes

Warom Explosion proof Distribution Boxes.
Modular GRP construction fitted with a variety of
optional components..

[Contact Us](#)



Distribution Boxes HRMD96 Series Explosion-proof Distribution Panels

·Equipped with specialized hinge structure, which
can prevent the flameproof joints from damage
when opening and closing the box, and greatly
prolong the service life of box. The boxes can be
combined

[Contact Us](#)

Explosion-proof and flame-retardant distribution box

The purpose of the present invention is to
provide an explosion-proof and flame-retardant
distribution box, which has good explosion-proof
and flame-retardant effect, strong impact



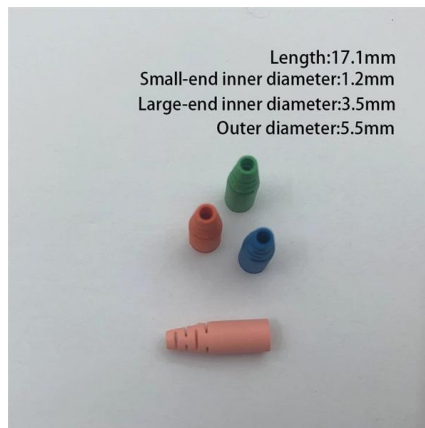

CE92 Explosion-proof power distribution boxes

CE92 Explosion-proof power distribution boxes
Category: Atex Junction Boxes

[Contact Us](#)



Tailored explosion-proof panel boards , Cortem S.p.A.

They are suitable for indoor or outdoor installation in chemical, petrochemical, refining plants and in any other industrial process with a potentially explosive atmosphere due to the presence of gas, vapors

[Contact Us](#)



Explosion-proof Distribution Box

China Explosion-proof Distribution Box catalog of Exd Explosion Prevention Exe Aluminum Alloy Junction Box Explosion-Proof Threading Straight Box Ex Seal Wire Box, Explosion-Proof Type a

[Contact Us](#)





How to Wire an Explosion-Proof Distribution Box and

Explosion-proof electrical equipment, such as explosion-proof distribution boxes, is specifically designed for hazardous environments where flammable gases,

[Contact Us](#)

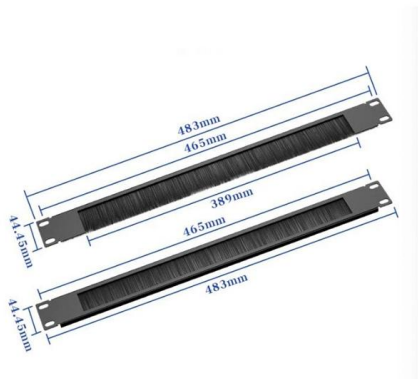

Ex Local Control Stations & Distribution Boxes

Atex control stations, explosion protected control units and distribution boxes made stainless steel maritime grade AISI 316L or AISI 304L. Atex Delvalle provides a

[Contact Us](#)



Application



Ex-Proof & Flameproof Enclosures & Junction Box , Supermec

All explosion-proof enclosures, lighting or power distribution boxes are manufactured using the latest technologies, both mechanical and electrical, using materials able to resist in most highly corrosive

[Contact Us](#)



Energy Distribution

BARTEC offers one of the most extensive ranges of explosion-proof and substance-resistant components, devices, and systems for controlling, switching, and

[Contact Us](#)



Special requirements for cable laying and distribution box installation

Working in potentially explosive environments means every component of your electrical system becomes a potential spark that could ignite disaster. It's not just about compliance - it's about

[Contact Us](#)



Explosion proof Enclosures and Distribution Boxes

For more information on our range of explosion proof enclosures and distribution boxes please click on the links above or contact us at ex@warom.ae

[Contact Us](#)

Explosion Proof Distribution Box , ATEX Transformer Supplier

We supply certified explosion proof distribution box & ATEX Transformer -Appleton, ATKON, CZ, CEAG, brands for safe and reliable industrial use.

[Contact Us](#)

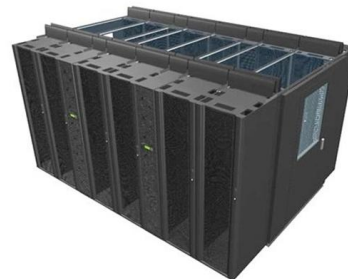

Control and Distribution Panels , Ex d , EJB Series

The enclosures are certified Ex d IIB+H2 and Ex tb as well as "explosion-proof". They are available in many sizes, a wide range of operating elements and

[Contact Us](#)



Ex d flameproof enclosure: design, advantages, limitations

The new concept involved the use of a thin-walled enclosure with so-called flameless explosion venting. Its task is to reduce the pressure inside the enclosure by

[Contact Us](#)



Principle and applicable area of explosion-proof distribution box

Because when explosion-proof distribution boxes are properly specified, installed, and maintained, they become invisible guardians. They represent the quiet professionalism of engineers

[Contact Us](#)

Explosion-Proof Electrical Distribution Boxes: Applications in

The implementation of explosion-proof distribution boxes greatly enhances personnel safety by preventing ignition of hazardous atmospheres. These enclosures also provide critical protection for

[Contact Us](#)



Terminal and Junction Boxes (Ex d) , Explosion Protection

Designed to withstand extreme temperatures, EJBX terminal boxes and junction boxes support operation in environments as cold as -60 °C. Customers can have each unit tailored to their

[Contact Us](#)

HLDP03-Series Explosion-proof Distribution Boxes Exporter China



Home >> Products >> Explosion Proof Electric Apparatus >> HLDP03-Series Explosion-proof Distribution Boxes

[Contact Us](#)



Explosion-Proof Distribution Boxes & Panels Manufacturer

The explosion-proof distribution box safely delivers power in hazardous zones (oil, gas, chemical plants) with rugged, spark-resistant casing--ATEX/IECEX, IP66 certified for reliable operation in explosive

[Contact Us](#)

HRMD91 Explosion proof Distribution Box (Ex d IIB+H2)

HRMD91 Explosion proof Distribution Box
Explosion protection to - IEC - CENELEC - NEC
Can be used in Zone 1 and Zone 2 Zone 21 and Zone 22 Class I, Zone 1

[Contact Us](#)



Explosion Proof Power Distribution Boxes CE92

Flameproof and explosion proof, these power overhaul distribution boxes are suitable for use in hazardous areas. Specs: Ex mark: Ex de IIC T4 Gb DIP A21 TA, T4

[Contact Us](#)



Distribution Boxes

Distribution Boxes BXM (D)8061 Explosion proof
Distribution Boxes Lighting or Power (Ex db ec
IIC)

[Contact Us](#)

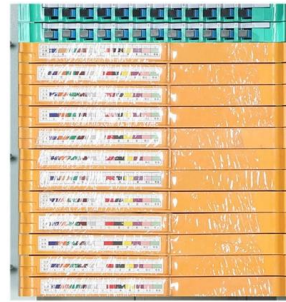

Distribution box solutions for explosion-proof environments in

These aren't just metal boxes; they're meticulously engineered fortresses designed to contain potential blasts and prevent disaster. Since the ATEX Directive came into force, equipment for explosive

[Contact Us](#)

Full Guide on Explosion-Proof Distribution Panel

Explosion-proof distribution panels are vital components in hazardous industrial environments, ensuring safety by preventing electrical equipment from igniting

[Contact Us](#)



Contact Us

For datasheets, pricing, or custom fiber access solutions, please visit:
<https://www.frindel.es>