

Elevator Building Main Distribution Box

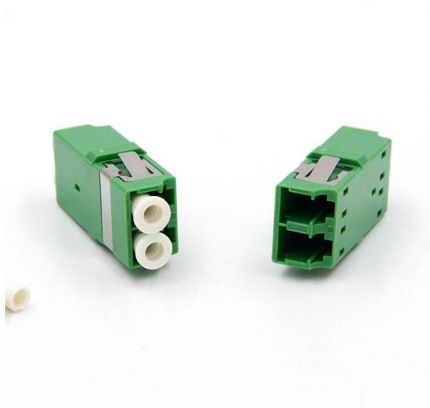



Elevator Building Main Distribution Box



Elevator control PB panelboard design guide

Not only does the Elevator Control Panelboard provide electrical feeds, it also contains necessary components for the control of the elevator and the fire alarm system.

[Contact Us](#)

Elevator control panelboard

Elevator control panelboard Eaton's elevator control panelboard is designed to meet the stringent requirements mandated by multiple building codes. These codes are designed to provide fire

[Contact Us](#)

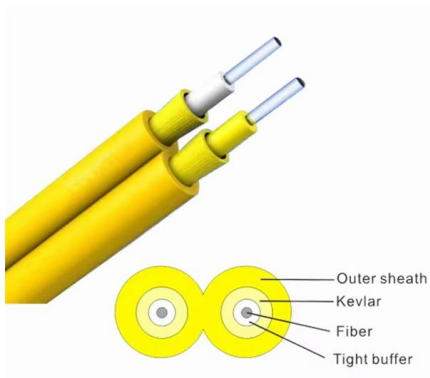

A Definitive Guide To Distribution Boxes

The distribution box acts as the center of power distribution, distributing electricity to all connected devices. A distribution box, also known as a distribution board, panel board, breaker

[Contact Us](#)

Quality Control for Installation and Construction of Electrical Riser

Master the key quality control methods for electrical riser & distribution box installation. Ensure safety, compliance, and prevent hazards in building electrical systems.



A Complete Guide to LV Distribution Board , CHINT global

LV distribution boards, part of the electrical distribution system, securely distribute low-voltage power to facility circuits.

[Contact Us](#)



The Essential Guide to Understanding Electrical

The electrical distribution system diagram plays a crucial role in understanding and managing power distribution within a building or facility. It provides a visual

[Contact Us](#)



The Critical Role of Power Distribution Boxes in Building Electrical

A power distribution box plays a central role in ensuring electricity is delivered correctly to different circuits and areas of a building. It helps control electrical flow, prevents overloads, and

[Contact Us](#)





What is the Internal Structure of The Distribution Box

What is a Distribution Box? Definition A distribution box is an essential electrical component used to manage and control the flow of electricity

[Contact Us](#)



Distribution Inside Large Buildings

Distribution Inside Large Buildings In large buildings the type of distribution depends on the building type, dimension, the length of supply cables, and the loads.

[Contact Us](#)

A Step-by-Step Guide to Understanding Elevator

It involves connecting the main power source to the main disconnect, as well as routing the power to various elevator components such as the motor, lights, and

[Contact Us](#)

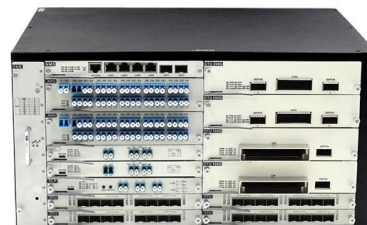

What is an Electrical Distribution Box? A

An electrical distribution box is often called the control hub of a building's electrical system, and for good reason. It's where power from the main

[Contact Us](#)



Understanding Elevator Wiring: A Comprehensive Diagram

Discover the essential components and connections in an elevator wiring diagram to understand how elevators operate with precision and safety.

[Contact Us](#)

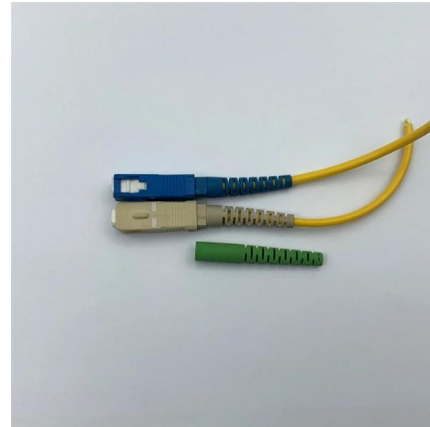

Distribution of Electricity in Multi-Storey Building

This is a fine, balanced, and decent system for the distribution of electricity within a multi-story building, owing to which, the beautification of the

[Contact Us](#)

Understanding Power Distribution Hierarchy in Buildings

Power distribution hierarchy in building. detailed explanation of DB, SDB, MDB, RMU, and Switchgear along with any commonly related equipment you might

[Contact Us](#)



Distribution Boxes: Types and Functions

A distribution boxes acts as the load center and main distributor of electrical power within a building. Also called a distribution board, panel board,

[Contact Us](#)



Electrical Rising Mains Layout , PDF , Elevator , Building

SLD FOR SB HOMESELECTRICAL RISING MAIN, COMMON AREA PANEL AND LIFT PANEL
16.11.2024-Model - Free download as PDF File (.pdf), Text File (.txt)

[Contact Us](#)

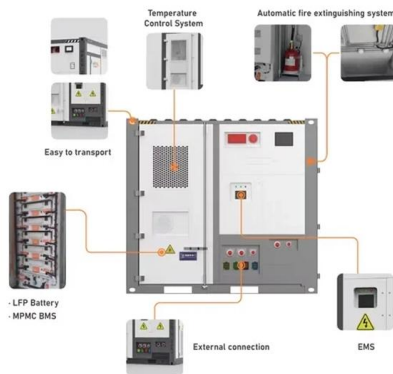

SECTION 16442

The equipment manufacturer shall have a minimum five years experience in producing UL 67 listed shunt-trip fused distribution panelboards with integral control wiring for elevator circuits.

[Contact Us](#)

0110-ElectricalRequirements-1124

Electrical Layout For Elevator Machinery Space
TRACTION (LLT) APPLICATION Controller G F I
Outlet Main Power (4" x 4" Box) Cab Light Power (4" x 4" Box)
Room Light and Switch Elevator & Hoistway

[Contact Us](#)



Distribution Panel Board, STAR ELEVATOR LTD

Key features of Main Distribution Boards offered by AGS: Fully type tested assemblies as per IEC 61439-1 Rated upto 6000A Rated operating voltage upto

[Contact Us](#)





Distribution boxes for elevators lighting and air conditioning designed

It is widely used in power supply for elevators, elevator shaft lighting and air conditioning in the building of industrial, commercial, residential and other fields.

[Contact Us](#)

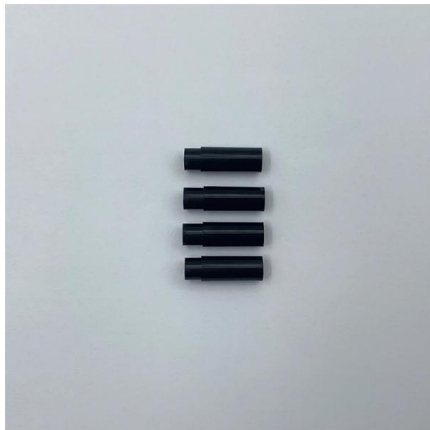

Distribution Board vs. Distribution Box: What's the

Understand the key differences between distribution boards and boxes--functions, applications, safety, cost, and when to use each one.

[Contact Us](#)

Distribution Box: Types and Functions , Axis-Electricals

A distribution box houses all the contact breakers, earth leakage units, doorbells, and timers. The electrical power supply comes from the network to the building

[Contact Us](#)



FRINDEL



Elevator Wiring and Control Diagram , PDF , Elevator

This document provides a wiring diagram for an elevator system. It shows the connections between various electrical components like the main

[Contact Us](#)



Understanding Distribution Boxes: A Comprehensive Guide

A distribution boxes is an essential device that manages the safe and efficient flow of electrical power throughout different areas of a building or facility.

[Contact Us](#)



Distribution boards components

Distribution boards (generally only one in residential premises) usually include the meter (s) and in some cases (notably where the supply utilities impose a TT earthing system and/or tariff

[Contact Us](#)

Electrical Distribution Boxes for Power Distribution , Wieland

From decentralized energy, signal and data distribution to distribution boxes for smart buildings, we offer the right solution. We mount any electronics in the manifolds! All options are open here, and the

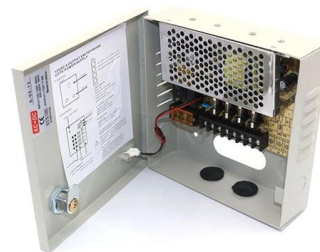

[Contact Us](#)



Understanding Distribution Boxes: A Comprehensive Guide

These boxes come in a variety of sizes and shapes depending on how complex a system is and the electric requirements of the building. A variety

[Contact Us](#)



Electric Meter Cabinet Complete Switchgear Power Distribution Box

Electric Meter Cabinet Complete Switchgear Power Distribution Box Aluminium Steel Withdrawable Unit for Elevator Control Cabinet is a crucial component of electrical systems, playing a vital role in safe

[Contact Us](#)

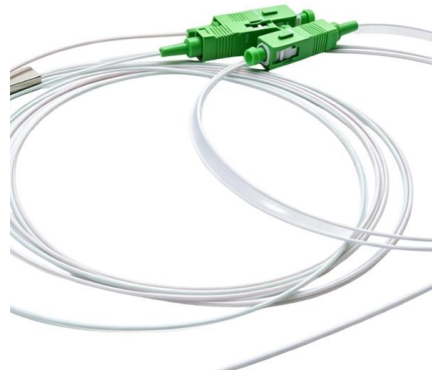

Understanding Distribution Boxes: Your Guide to Power

What are Distribution Boxes and Their Importance? What are Distribution Boxes and Their Importance? Distribution boxes, or electrical junction

[Contact Us](#)

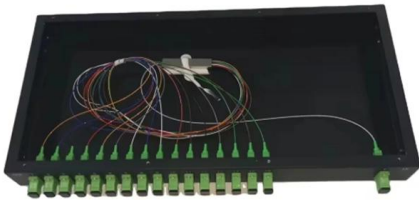

Contact Us

For datasheets, pricing, or custom fiber access solutions, please visit:
<https://www.frindel.es>