

Distribution box missing door





Distribution box missing door



Common Issues and Troubleshooting for 3 Phase Electrical

This blog explores common problems associated with 3-phase power distribution boxes and offers practical troubleshooting tips to keep your system running smoothly.

[Contact Us](#)

How to solve and prevent the failure of the distribution

To sum up, qualified construction and maintenance operations, in conjunction with standards and safety measures, can effectively prevent and solve distribution box

[Contact Us](#)



Replacement Door

You can easily replace a damaged or missing meter box door without the need for professional assistance, making it a cost-effective choice for maintaining the

[Contact Us](#)

Most Common Septic Tank Distribution Box Problems And Solutions

Weather is also responsible for some of the common problems with septic tank distribution boxes. For instance, when it rains heavily, flooding and overflow of the D-box may be

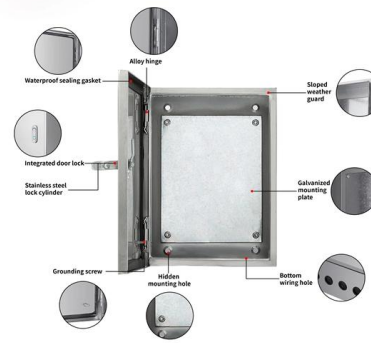

Length:14.5mm
 Small-end inner diameter:2.0mm
 Large-end inner diameter:3.5mm
 Outer diameter:5.2mm



Distribution board

A distribution board (also known as panelboard, circuit breaker panel, breaker panel, circuit breaker, electric panel, fuse box or DB box) is a component of an electricity supply system that divides an

[Contact Us](#)

Distribution Box Replacement and Repair

Distribution box repairs or replacements are a common service. This is because they are made of thinner pre-cast concrete than that of tanks. The hostile environment

[Contact Us](#)



Comprehensive Guide on Septic Distribution Box

Learn how to replace your septic distribution box with this comprehensive guide, ensuring proper function and safety.

[Contact Us](#)

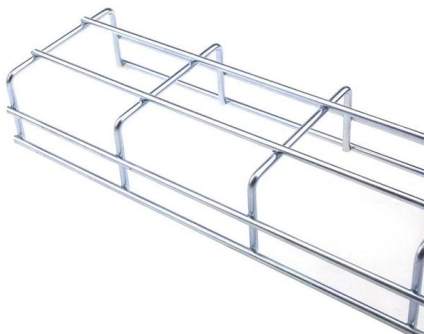

Distribution Boxes Installation & Repair ,



River Valley

If there's a problem with your distribution box, it could cause costly damage to your entire septic system. Our experts at River Valley Septic have years of experience

[Contact Us](#)

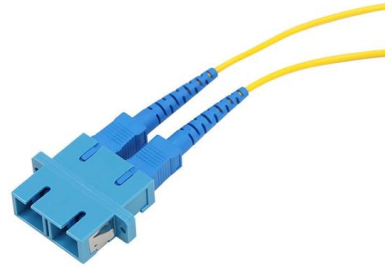

Common Issues with Distribution Boards and How to Address Them

Distribution boards are crucial to any building's electrical system. They distribute electricity to different circuits, ensuring that power flows smoothly and safely throughout the

[Contact Us](#)



What are the common problems of distribution boxes?

The main problems encountered with distribution boxes include installation and layout problems, electrical connection and grounding problems,

[Contact Us](#)



How to solve the problem of distribution box?

If you're not sure, it's best to contact a professional electrician for repairs. Preventive measures: Once the fault is resolved, regular inspection and maintenance of the distribution box is recommended to

[Contact Us](#)





Distribution Box Guide: Types, Components & Solutions

Understand distribution boxes (DB boxes) in 5 minutes. Learn about types, components, functions, and uses. Find the perfect DB box for your needs.

[Contact Us](#)



How to solve the problem of distribution box installation

The iron sheet of the distribution box is too thin and the rigidity is poor, forming severe deformation between the shell and the door surface, and the sealing gap

[Contact Us](#)



How to solve the problem of distribution box?

Here are some solutions when a power distribution box fails: Safety First: Make sure you are safe. Do not touch live parts, turn off the corresponding power switch to avoid the risk of electric shock. Check

[Contact Us](#)

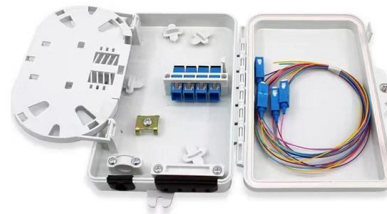

Distribution Boxes Explained: Types, Functions, and

Learn about distribution boxes, their types, functions, and safety features to ensure efficient and secure electrical power distribution in any building.

[Contact Us](#)



What Is a Distribution Box?

What to Look for When Choosing a Distribution Box If you're going to buy a distribution box, there are several things you should look for. You should

[Contact Us](#)

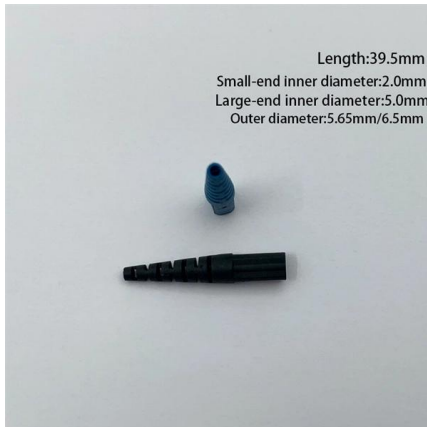

Distribution box

Yet the distribution box is a highly complex component that not only ensures safe power distribution, but is also responsible for protection in an emergency. In this article, you will learn everything you need

[Contact Us](#)

Help! Missing Panel and Door!

I'm a new homeowner and out circuit box is missing the panel and the metal door. The previous owners thought they'd spruce up the cover and apparently didn't care all that much about

[Contact Us](#)



How to Replace a Septic Distribution Box

The distribution box of the septic tank system is used to evenly distribute the wastewater from the septic system to the dispersal field. Over time,

[Contact Us](#)



Help! Missing Panel and Door!

Missing Panel/Door! Missing Panel/Door! My name is Steve and I'm looking for some guidance. I'm a new homeowner and out circuit box is missing the panel and the metal door. The

[Contact Us](#)



Power Distribution Boxes Explained Simply

Learn what a power distribution box is, how it works, key components, types, and why it's vital for safe and efficient electrical systems.

[Contact Us](#)

Repair or replacement steps for distribution box door lock failure

If you're dealing with a stubborn distribution box door lock that won't budge or seems worn out, you're in the right place. Let's walk through how to diagnose and fix this common issue step-by

[Contact Us](#)

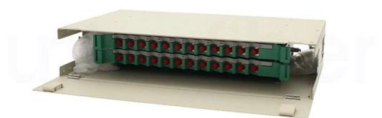

Full Guide to Understanding Septic Tank Distribution

Find out the crucial key to solving septic tank distribution box problems for optimal system performance - don't miss this essential guide!

[Contact Us](#)



Contact Us

For datasheets, pricing, or custom fiber access solutions, please visit:
<https://www.frindel.es>