

Distribution box distribution cabinet switch





Distribution box distribution cabinet switch



Power Distribution Cabinet - Types, Functions & Uses

Power distribution cabinet explained! Learn types, functions, and uses in industries. Discover DSY cabinets for safe, reliable power management.

[Contact Us](#)

Understanding Distribution Boxes: A Comprehensive Guide

In general, a distribution box is mainly used to distribute electrical power to multiple circuits and provide circuit protection. An electrical panel may

[Contact Us](#)



The purpose, working principle, and usage instructions

The power distribution box and lighting distribution box should be set separately. (4) All electrical equipment on the construction site must have their

[Contact Us](#)



Understanding Distribution Boxes:A Comprehensive Guide

Understanding its significance, this article covers what a distribution box is, how it functions, its structure, the various types available, and how it

[Contact Us](#)



Distribution Box Guide: Types, Components & Solutions

Understand distribution boxes (DB boxes) in 5 minutes. Learn about types, components, functions, and uses. Find the perfect DB box for your needs.

[Contact Us](#)

Power Switching and Distribution Cabinets

Power Switching and Distribution Cabinets
Vertiv(TM) Liebert® RXV Distribution Unit
The Liebert® RXV remote power distribution cabinet provides dense power distribution in a small footprint, with up to

[Contact Us](#)

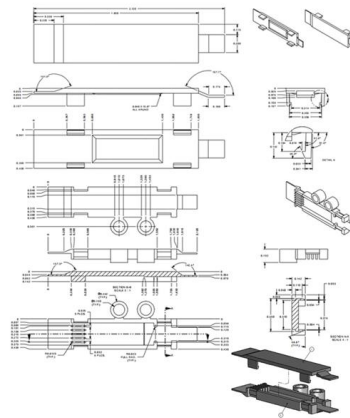

Distribution Boxes Explained: Types, Functions, and

Learn about distribution boxes, their types, functions, and safety features to ensure efficient and secure electrical power distribution in any building.

[Contact Us](#)



What are the differences between distribution boxes,

In addition to differences in function, installation environment, internal structure, and controlled objects, the notable characteristics of distribution boxes

[Contact Us](#)



The difference of Distribution box, distribution cabinet

1. Conceptual distinction (1) Distribution box The distribution box is a small power distribution box, which contains power switch and safety device. The structure is

[Contact Us](#)



On the difference of distribution box, distribution cabinet, switch

The distribution box is small, can be hidden on the wall, can stand on the ground. The cabinet is very large, only the equipment is in the substation and distribution room.

[Contact Us](#)



Difference Between Control Box, Control

Control Box: Control boxes manage the switching and operation of electrical equipment. Located near machinery, they provide centralized control for

[Contact Us](#)





The Ultimate Guide to Distribution Box Types

Discover the key types of distribution boxes with NUOMAK's comprehensive guide. Learn about Main Distribution Boards (MDB), Consumer Units, Transfer

[Contact Us](#)



Distribution cabinets great prices at reichelt elektronik

KNX binary inputs receive digital signals from sensors or switches and integrate them into a KNX home automation system. View all 8 items

[Contact Us](#)

Distribution Boxes, Switch Outlets and Accessories

Our products range includes simple flush-mounted switch boxes to surface-mounted boxes for indoor use, as well as high-end IP65 junction boxes for use in wet areas.

[Contact Us](#)



What is the difference between the manufacturer's explanation of

It is often set in substation, distribution room, etc. In addition to different functions, installation environment, internal structure and controlled objects, the remarkable characteristics of distribution

[Contact Us](#)



Panelboards and Distribution Panels: What They Are

Introduction Navigating the world of electrical distribution can be confusing, with terms like panelboard, switchboard, and distribution box often

[Contact Us](#)

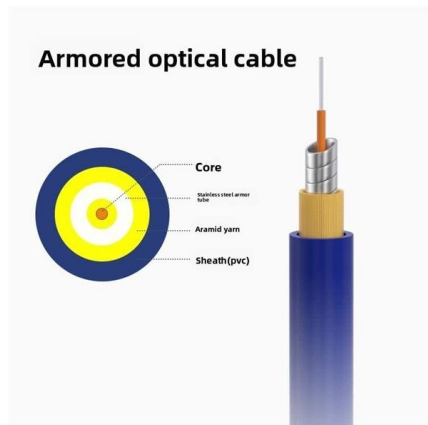

The Complete Guide to Distribution Box: Installation, Types & More

Understanding the key components of a distribution box helps you make informed decisions about installation and maintenance. Each element plays a specific role in ensuring safe

[Contact Us](#)

Basic knowledge of distribution cabinet and distribution box

Function: it is mainly used to distribute energy, distribute the main power supply to each power branch switch, and connect and disconnect the branch power supply

[Contact Us](#)



What is the difference between a distribution box and a switch box

Whereas a distribution box is designed to distribute electricity, a switchboard is used to operate and control electrical devices or processes. When specific applications or environments call

[Contact Us](#)





What is the Internal Structure of The Distribution Box

Learn about the internal structure of a distribution box, its components, functions, and key types. Understand its role in electrical systems

[Contact Us](#)



The Difference Between Switchgear and Distribution

There are differences in installation sites: switchgear cabinets are often set up in substations, distribution rooms, and other places. Distribution cabinets

[Contact Us](#)

Uncovering the Secrets of Power Distribution Cabinets:

Explore power distribution cabinets! This comprehensive guide unveils secrets of PDUs, electrical centers, and power distribution in data centers.



[Contact Us](#)

Contact Us

For datasheets, pricing, or custom fiber access solutions, please visit:
<https://www.frindel.es>