

Cost-effectiveness of Chinese stockpiled cable trays





Overview

China remains the dominant global hub for cable tray manufacturing, supplying ~68% of the world's market (2025 CMRA Data). While cost advantages persist, 2026 procurement strategy must prioritize cluster-specific capabilities, compliance maturity, and supply chain. Cable trays are essential for organizing and protecting electrical wiring in industries ranging from power generation to manufacturing. Global Outlook - By Type (Ladder Type Cable Trays, Solid Bottom Cable Trays, Trough Cable Trays, Channel Cable Trays, Wire Mesh Cable Trays, Single Rail Cable Trays), By Material Type (Steel, Stainless Steel, Aluminum, Other Material Types), By Finishing (Galvanized Coatings, Pre-Galvanized). Factories can produce galvanized steel, stainless steel (AISI 304/316), and aluminum trays at scale while maintaining tight tolerances ($\pm 1\text{mm}$) and compliance with international standards like IEC 61537. Local availability of CNC punching, laser cutting, powder coating, and deep-drawing operations. Cable tray pricing represents a crucial consideration in modern electrical infrastructure projects, encompassing various factors that influence the overall cost-effectiveness of cable management systems.



Cost-effectiveness of Chinese stockpiled cable trays



Building Better: The Omni Guide to Cable Tray Value

There are many types of cable tray styles, sizes, fittings, materials, and applications that Omni can recommend. Experience and detailed planning of

[Contact Us](#)

How Cable Tray Systems Help Reduce Construction Costs , Expert

Hutaib Electricals is a premier construction cable tray manufacturer in India, specializing in high-quality, customizable cable tray systems. Enhance your projects with our durable solutions

[Contact Us](#)



What are the Top 6 China Cable Tray Manufacturers?

The Top China Cable Tray Manufacturers play a pivotal role in supplying high-quality, cost-effective cable management solutions to industries

[Contact Us](#)

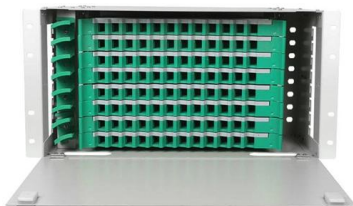

Cable Trays Market Size, Share & Growth Trend Report

The global cable trays market stood at USD 6.37 Billion in 2025 and may hit USD 17.60 Billion by 2035, with a CAGR of 10.70%.

[Contact Us](#)

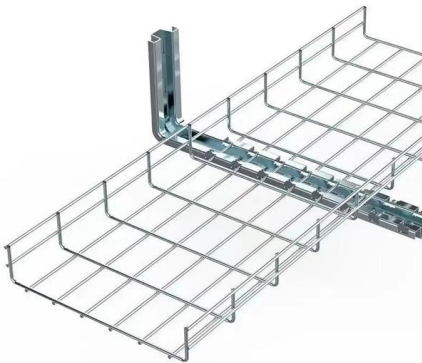

Strategic Sourcing of Cable Trays: Supplier Selection & Cost

Evaluate cable tray suppliers based on material compliance, production capacity, and operational reliability. Compare pricing, MOQs, and customization options from leading Chinese manufacturers

[Contact Us](#)

Premium Cable Tray Systems from China: Advanced Cable

Discover high-quality cable tray systems manufactured in China, featuring advanced corrosion protection, versatile designs, and comprehensive quality control for reliable cable management

[Contact Us](#)

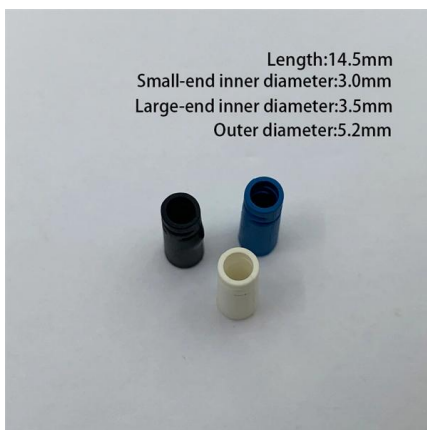
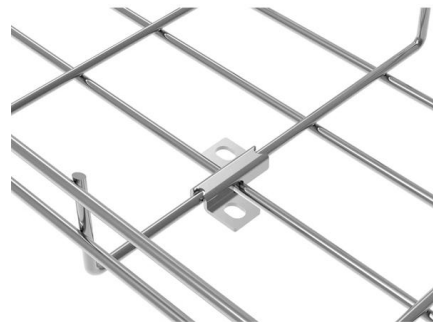

A method for the cost optimization of industrial electrical routings

ABSTRACT The cost reduction is one of the most spread strategy adopted by companies for guaranteeing prof-its in a competitive market. This paper presents an approach for the cost

[Contact Us](#)



Cut Costs by 15%: Cable Tray Supply Chain

Learn how to optimise the cable tray supply chain, from raw material procurement to delivery, with strategies to boost efficiency and reduce costs.

[Contact Us](#)



Cost-Effective Cable Tray Systems for Efficient

Discover why cable tray systems are a cost-effective solution for organized, safe, and scalable cable management in commercial and industrial setups.

[Contact Us](#)

What are the Top 6 China Cable Tray Manufacturers?

In this guide, we've curated the Top 6 China Cable Tray Manufacturers for 2025, spotlighting three standout companies--including

[Contact Us](#)

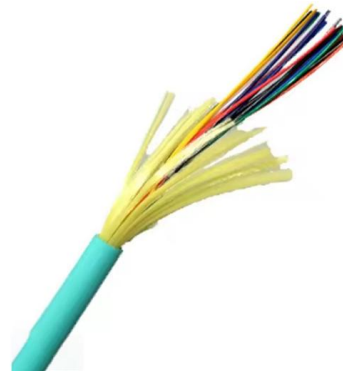

Cable Trays Market

Steel cable trays hold approximately 49% of the market due to their superior strength, load-bearing capacity, and cost-effectiveness. Steel's high

[Contact Us](#)



Sourcing Cable Tray Manufacturer from China: The Ultimate Guide 2026

China remains the dominant global hub for cable tray manufacturing, supplying ~68% of the world's market (2025 CMRA Data). While cost advantages persist, 2026 procurement strategy

[Contact Us](#)



How Cable Tray Systems are Changing Electrical

Explore the evolution and smart innovations in cable tray systems that enhance electrical infrastructure efficiency.

[Contact Us](#)



Top 10 Cable tray manufacturing China Products Compare 2025

Are you in the market for high-quality cable trays but overwhelmed by the options? With China being a powerhouse in manufacturing, understanding the top cable tray factories can make all the difference

[Contact Us](#)

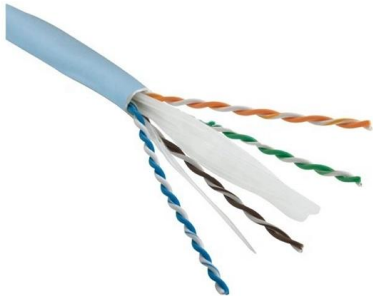

Cable Tray Manufacturing Cost Analysis

The document outlines the manufacturing process and specifications for cable trays and containment products, including types, benefits, and applications. It provides

[Contact Us](#)



Cable Tray Cost Comparison

Compare cable tray costs by type, material, and installation. Find the most cost-effective option for your project in this detailed buyer's guide.

[Contact Us](#)

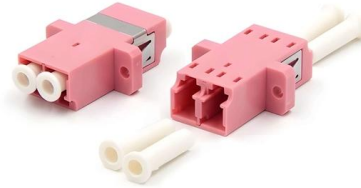

Cost Efficiency of Using Stainless Steel Ladder Cable Trays in

How do stainless steel ladder cable trays compare to aluminum in terms of cost? While stainless steel has a higher initial cost than aluminum, its durability and lower maintenance needs often make it

[Contact Us](#)

China Cable Trays, Cable Trays Wholesale, Manufacturers, Price

Are there cost-effective ways to buy cable trays wholesale? The Cable Trays is a standout piece in our Cable Tray collection. Yes, purchasing from a reliable distributor can offer cheap options without

[Contact Us](#)



Cable Tray, Cable Trunking, Cable Ladder, Perforated

Wire mesh cable tray is the light weight to medium duty easy-to-install cable management system which can provide point-to-point pathways for cables with

[Contact Us](#)





Cost-Effective Solutions: The Advantages of Cable Trays

This article examines the reasons behind the popularity of cable trays as a cost-effective method for organising wiring systems and discusses their benefit.

[Contact Us](#)



Comprehensive Guide to Cable Tray Pricing: Cost-Effective Solutions

Explore detailed insights into cable tray pricing, including material options, installation benefits, and long-term value considerations for optimal cable management solutions in commercial and industrial

[Contact Us](#)



Comprehensive Cable Tray Pricing Guide: Cost-Effective Solutions for

Cable tray pricing represents a crucial consideration in modern electrical infrastructure planning, encompassing various factors that influence the overall cost-effectiveness of cable management

[Contact Us](#)



Effective Cable Storage Solutions for Homes and Businesses in China

Comprehensive Guide to Cable Storage Solutions in China Cable storage is a critical aspect of managing electrical and communication systems in various industries. In China,

[Contact Us](#)

100G QSFP28 to 4*25G SFP28 AOC
QSFP-4X25G-AOC**M

100 SFP+ AOC
SFP-100G-AOC**M
1m 2m 3m 5m 7m 10m 15m 20m 25m 30m

25G SFP28 AOC
SFP28-25G-AOC**M
1m 2m 3m 5m 7m 10m 15m 20m 25m 30m

100G QSFP28 AOC
QSFP-100G-AOC**M
1m 2m 3m 5m 7m 10m 15m 20m 25m 30m

AOC
10G 25G
40G 10G

40G QSFP+ to 4*10G SFP+ AOC
QSFP-4X10G-AOC**M

40G QSFP+ AOC
QSFP-40G-AOC**M
1m 2m 3m 5m 7m 10m 15m 20m 30m 50m



Cable Tray Market Size, Share, Industry Report 2035

Tariffs are affecting the cable tray market by increasing the cost of imported steel, aluminum, and surface-treated metal components used in ladder, wire mesh, and

[Contact Us](#)



Contact Us

For datasheets, pricing, or custom fiber access solutions, please visit:
<https://www.frindel.es>